

**This product may be purchased from Connevens Limited secure online store
at www.DeafEquipment.co.uk**



DeafEquipment.co.uk
Solutions to improve the quality of life



ILD100 HANDBOOK

Handbook Contents

- Safety
- Introduction
- Quick Start
- Overview
- Installation
- Troubleshooting
- Accessories
- Technical Specification
- Warranty
- Declaration of Conformity

Box Contents

- 1 x ILD100
- 1 x Installation & Commissioning Handbook
- 1 x Power Cable
- 1 x Designing Induction Loops Handbook



This symbol is used to alert the user to important operating or maintenance instructions.



The Lightning bolt triangle is used to alert the user to the risk of electric shock.

SAFETY:

1. It is important to read these instructions, and to follow them.
2. Keep this instruction manual in an accessible place.
3. Clean only with a dry cloth. Cleaning fluids may effect the equipment.
4. Do not cover or obstruct ventilation of this unit. Install in accordance with the manufacturer's instructions.
5. Do not install near any heat sources such as radiators, heating vents, or other apparatus that produces heat.
6. Refer all servicing to qualified personnel. Servicing is required when the apparatus has been damaged in any way, such as a power supply cord or plug is damaged, liquid has been spilled or objects have fallen into the apparatus, the apparatus has been exposed to any rain or moisture, does not operate normally or has been dropped.
7. **WARNING** - To reduce risk of fire or electric shock, do not expose this apparatus to rain or moisture. The apparatus shall not be exposed to dripping or splashing and no objects filled with liquids, such as vases, shall be placed on the apparatus.



CAUTION
RISK OF ELECTRIC SHOCK
DO NOT OPEN

TO PREVENT ELECTRIC SHOCK DO NOT REMOVE THE COVER. THERE ARE NO USER SERVICEABLE PARTS INSIDE. REFER SERVICING TO QUALIFIED PERSONNEL.

INTRODUCTION

The ILD100 has been designed as a high quality amplifier for small to medium size induction loop systems in places such as video conference facilities, meeting rooms, small seminar rooms, TV rooms, nursing homes, private homes, reception and waiting rooms.

The ILD100 can cover areas up to 120m² for a square loop and greater than 200m² for a rectangular loop configuration.

The ILD100 has two microphone inputs suitable for electret microphones and twin Phono line inputs suitable for direct connection to a TV set via SCART style connection, or connection to a Hi-Fi system. The unit has VOX switching capabilities which are controlled by selecting appropriate switches.

QUICK START

For those who have a good appreciation of loop systems, the following is a very quick guide to setting up the amplifier:

All you need is a power source, a signal source and a loop. See 'Designing Induction Loops' handbook (supplied) or contact Ampetronic for advice.

Installation

1. Turn all controls fully anti-clockwise.
2. Connect loop cable of appropriate length / gauge.
3. Connect signal input(s).
4. Connect power.

Operation

5. Switch on Check green Power LED is illuminated.
6. Apply input signal and increase the input control until the Compression LED begins to light.
7. Adjust the Drive control until the Loop Current LED begins to light on the peaks of the signal.
8. Repeat step 6 for the other inputs if used.
9. Listen to the magnetic field produced inside the loop area using a receiving device (e.g Ampetronic ILR3), or examine the performance in more detail with a suitable field strength meter.
10. Adjust the TONE control to achieve a flat frequency response.

OVERVIEW

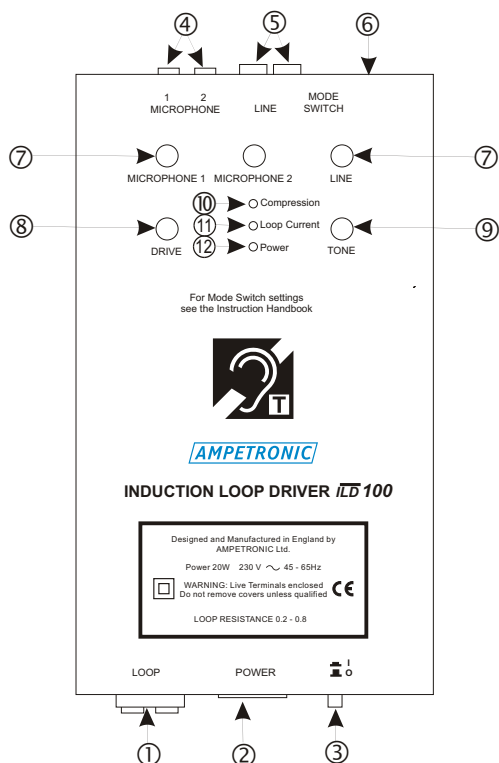

- ① LOOP output connector.
- ② AC POWER: standard 2 pole IEC320 "Figure 8 style" connector.
- ③ I/O: Power switch.
- ④ MICROPHONE inputs: 3.5mm mono jack connectors.
- ⑤ LINE input: Twin RCA (Phono) connectors, for stereo connection.
- ⑥ VOX MODE SWITCH: Switches 1,2 & 3.
- ⑦ MICROPHONE 1, 2 and LINE: Screwdriver adjustable controls which set the gain and level of signal fed to the compressor.
- ⑧ DRIVE: Screwdriver adjustable control which sets the level of output current delivered to the loop.
- ⑨ TONE: Screwdriver adjustable control allowing adjustment to the system frequency response.
- ⑩ Compression LED: shows input signal has reached the compression point.
- ⑪ Loop current LED: indicates when current is running into the loop.
- ⑫ Power LED: Indicates power is applied to the unit and is switched on.

OVERVIEW cont'd

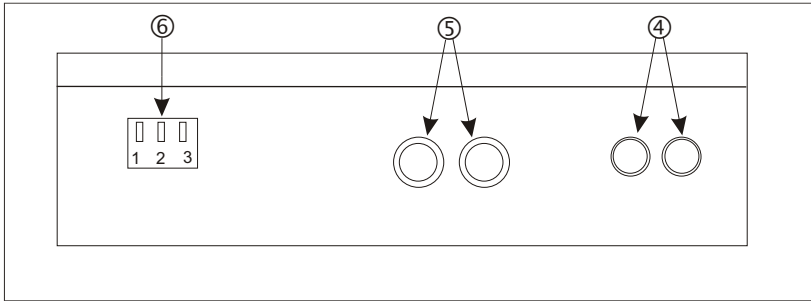

- ④ MICROPHONE inputs: 3.5mm mono jack connectors.
- ⑤ LINE input: Twin RCA (Phono) connectors, for stereo connection.
- ⑥ VOX MODE SWITCH: Switches 1,2 & 3.

ILD100 Block diagram

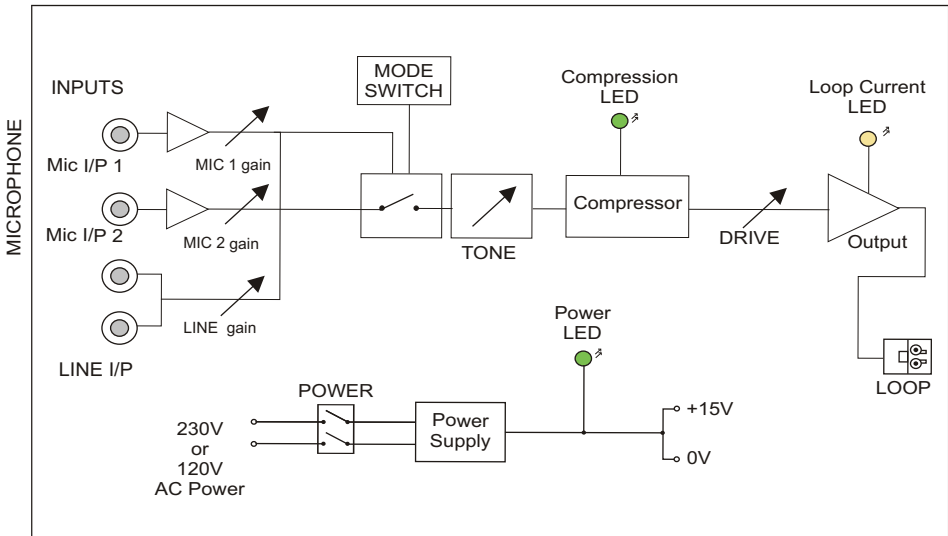

INSTALLATION

Location:



- When installing this equipment ensure adequate ventilation as the equipment dissipates heat during operation.
- The unit can be placed freestanding, or wall mounted using two No 8 Round Head wood screws fitted to suit the rear hole pattern. The screws are positioned at 160mm separation in a vertical line. The drilling template supplied will assist in correct positioning.

Choice of loop Cable:

- The maximum DC resistance of the loop should be greater than 0.2 for optimum performance, but should be less than 0.8 .
- The cable from the loop to the ILD100 output terminals MUST be a twisted pair. If this is longer than 10 metres, contact Ampetronic.

Tools & Equipment:

- Small hand tools including a wire stripper and a small flat bladed screwdriver.
- An ILR3 loop receiver or a magnetic field strength meter is vital to check that the loop system is providing the desired level of performance.

System Requirements:

- The induction loop cable itself should be already installed according to the “Designing Induction Loops” handbook, or as per specific design instructions provided by Ampetronic. As a result, a target peak current should be known, based on achieving acceptable field strength across the area to be covered.

Microphone Inputs:

- Both inputs are designed to be used with an unbalanced microphone as supplied with the equipment. Power for the microphone is supplied from the equipment. Some unbalanced electret microphones with internal battery can be externally powered if this internal battery is removed. Many microphones of this type are adversely affected by the external DC power, even when using their internal batteries. In all these instances, careful investigation will indicate whether a microphone is suitable.
- Dynamic microphones cannot normally be used with the equipment, because of the much lower signal level, also the DC bias seriously impairs the performance of the microphone. Ampetronic can supply a special adaptor which permits the use of dynamic microphones (and electrets which are affected by the DC bias).
- The cable length on this input must not exceed 3 metres, as unbalanced microphone lines are susceptible to interference. EMC compliance is only met for this cable length. The above mentioned adaptor converts the input to a balanced line, which can be extended to longer distances.

Line Input:

- A twin phono input is fitted to the unit, allowing a direct connection to the Left and Right channels of the SCART signal, or the output from a HiFi system. It is also possible to connect the line-level output of another sound system to this input.
- Maximum cable length on this input should be less than 3 metres so as to ensure EMC compliance.

Connection & Set-up:

During the initial commissioning of the equipment it is essential that the following procedure be used to ensure a satisfactory end result.

1. Turn the MICROPHONE, LINE and DRIVE controls fully anti-clockwise, i.e. minimum signal, and set the TONE Control to mid-range position.
2. Provide a continuous input signal, preferably from a small tape/CD player with speech or music, connected to the LINE input.
3. Increase the LINE control until the compression LED illuminates under peak signal conditions. This establishes a reference level for the output power driver.
4. Increase the DRIVE setting until the desired output current is achieved. If no reading is obtained, check for loop continuity.

5. Listen to the magnetic field produced inside the loop area using a receiving device (e.g Ampetronic ILR3), or examine the performance in more detail with a suitable field strength meter.
6. From this point onwards, the DRIVE control will not need re-adjusting, as this only affects the peak field strength.
7. Connect the cable from the audio system to the line input, and re-adjust the input gain control for optimum compression. If only the microphone input is used directly, without another sound system, then set up the entire system from a normal sound source activating the microphone(s). Ideally, adjust the MICROPHONE input with the lowest level of sound.
8. At this point the TONE control can be adjusted to give the best frequency response, which can be checked with an ILR3 or field strength meter.

Setting of input controls - Optimising Compression - VOX levels.

In order to obtain the greatest possible dynamic control range from the compressor it is now necessary to establish the highest level of input signal which the equipment may receive in the operational installation. This will often be loud, close talking into a microphone.

It should be pointed out here that background hum and noise from equipment earlier in the chain, such as a sound or TV system may sound unpleasant when subjected to some 20-36dB extra amplification.

When this occurs, the gain must be kept at a lower, acceptable level. Where the dominant signal is music, then it may be important to keep the compression level low, to prevent serious degradation of the music dynamics. Experience will indicate which level to use.

REMEMBER: once the DRIVE control has been set, only adjust the MICROPHONE or LINE control, as otherwise the correct operation of the equipment is impaired.

Voice Controlled switching (VOX)

There are 3 MODE select switches for the VOX switching features of the ILD100. These switches are located on the top edge of the unit alongside the input connectors. See Overview. The MODE select switches enable their respective functions when in the 'ON' position (the switch is down, towards the base of the unit). The mode select switches may be used in the combinations shown below to achieve the required effect.

The VOX threshold is at the onset of compression, and as such is automatically set by the MICROPHONE and LINE controls.

Switch Position 1 2 3	Effect when Microphone 1 signal is higher than VOX threshold	Effect when Microphone 1 signal is lower than VOX threshold for > 5 seconds.
off off off	Vox switching disabled - all inputs operate normally	
off off on	Microphone 1 input on.	Microphone 1 input off.
off on off	All inputs attenuated by 15dB except Microphone 1	All inputs at normal levels
off on on	All inputs attenuated by 15dB except Microphone 1	All inputs at normal levels except Microphone 1 input off
on X X	Reserved for future use.	

TROUBLESHOOTING

No power LED:



Check that power has been connected to the unit and the POWER is switched on (I/O button pressed in).

Check Mains power connector fuse.

Check Mains power is available at the socket.

No Compression LED:

Check that a microphone or signal source is connected and the corresponding input control has been set. Check VOX switch settings.

No Loop Current LED:

Check that the compression LED is illuminated.

Check that the Drive control has been set.

Check that the loop cable is properly connected and is not open circuited; check with a suitable multimeter that the resistance of the loop is between 0.2 and 0.8 Ohms.

Instability or high frequency noise:

1. It is possible for the loop cable to become shorted to ground under fault conditions, resulting instability which may sound like high frequency noise, buzz or whistling.

The results of this type of fault are likely to cause the unit to overheat. This fault is easy to determine. Simply disconnect the loop cable from the amplifier and test with a resistance meter between the loop cable and earth. There should be an open circuit measured between the earth/chassis and cable, if not, investigate the fault.

2. Instability can be caused by using poor quality signal cables, long unbalanced (2-wire) signal runs to the inputs, or by running input cables in close proximity with the loop wire over any appreciable distance.

Loop amplifiers are capable of delivering high currents at audio frequencies. If the loop cable is run close to sensitive signal cables it may be possible to induce a signal back into the input of the amplifier causing feedback. Cable runs and loop wires should be kept well apart from each other. To avoid interference a proximity of 300mm should only be run for a few meters.

Interference

1. Background magnetic field signals or interference may be present in any location and may not be anything to do with the loop system. Monitor this with a loop receiver (such as an ILR3). If the interference is still present with the loop system switched off, then you need to locate and eliminate the source of interference before switching the loop system back on.
2. AC power hum can be introduced into the system if signal cables are grounded at multiple points. This can cause earth currents to flow around the screen wires of signal cables and introduce unwanted noise into the audio path.
3. Magnetic fields can be induced into any low impedance electrical path or loop. Multiple ground earth systems may experience the pick up of the loop signal, and cause difficulties with other systems that are not designed to reject such interference. Check entire sound system for evidence of loop signal, and trace source of pick-up.
4. Under certain circumstances, the loop signal may appear as jagged lines or hum bars on a CCTV picture. This could be due to running CCTV (low impedance unbalanced 2-wire circuit) cables in close proximity to the loop cable. Separate the cables to reduce the effect.
5. Remote (and apparently unconnected) PA systems can sometimes pick up loop signals. This is usually because the loop cable becomes damaged (see point 1 of Instability) or induces signals into the remote system through long unbalanced cables. Always run long audio signal cables as 3-wire balanced circuits & keep away from loop cables.
6. See also point 1 of Instability.

ACCESSORIES

Details of all products & services provided by Ampetronic can be found at www.ampetronic.com

Desktop Microphone EM195A, or Boundary Microphone Q400, or Tieclip style Microphone EM336, are available if required.

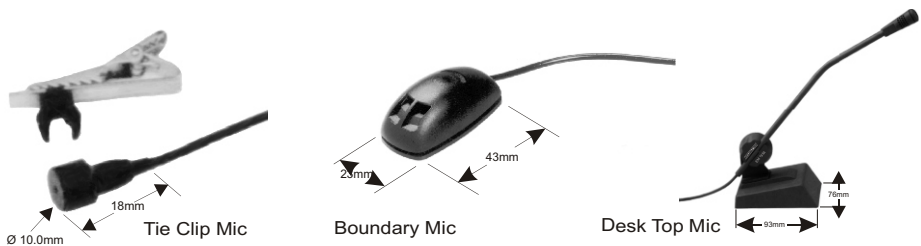

TECHNICAL SPECIFICATIONS

AC Power Supply:

2-pole IEC320 "Fig-8" connector.
20W nominal for either version.
45-65Hz.

230V Version

Nominal: 230V AC.
Fuse: T 100mA L.
Range: 207-253V AC.
Quiescent current: 48mA.
Typical current: 85mA
(O/P $1.6A_{RMS}$ pink noise).

120V Version

Nominal: 120V AC.
Fuse: T 200mA L.
Range: 108-132V AC.
Quiescent current: 108mA.
Typical current: 170mA
(O/P $1.6A_{RMS}$ pinknoise).

MICROPHONE Input:

2 x 3.5mm mono inputs.
Input Impedance: 8k
Sensitivity: $-60dBu$ ($775\mu V_{RMS}$)
for full output.
Overload: $>-12dBu$ ($200mV_{RMS}$).

LINE Input:

Twin RCA (phono) inputs.
Input Impedance: 20k between
each input 60k single input.
Sensitivity: $-30dBu$ ($24mV_{RMS}$)
for full output.
Overload: $>+10dBu$ ($2.45V_{RMS}$).

Compression (AGC):

$>36dB$ dynamic range.
Controlled by adjusting input level.

Loop Design:

Depends on application, see
Designing induction loops
handbook(supplied) or
consult Ampetronic.

Output:

Current: $>4.5A$ peak into 0.8
Voltage: $>4V$ peak.
Loop Resistance: 0.2 to 0.8
resistive or 1.0 max impedance
reactive at 1.6kHz.
THD+N $<0.5\%$ @ 1kHz @ $4.8A_{pk}$

Frequency Response:

Measured at low level with no
metal loss correction.
80Hz to 6.5kHz $-3.0dB$.

Environmental:

Ventilation: See **Installation**
section for details.
Ambient temperature: 0C to $+35^{\circ}C$
Relative Humidity: $<90\%$.
IP rating: IP20.

Physical: Weight: 1.3kg
Width: 124mm
Depth: 216mm
Height: 44mm

Options:

Microphone options - see
Assessories.

Standards:

Meets relevant CE, EMC and
safety standards.

*Please contact Ampetronic if you
need further assistance.*

WARRANTY

This product carries a five year parts and labour warranty which could be invalidated if these instructions are not followed correctly, or if the unit is misused in any way.

The five year warranty is dated from the time the equipment leaves Ampetronic and NOT when it is installed.

DECLARATION OF CONFORMITY

Manufacturer: Ampetronic Ltd.
Northern Road,
Newark,
Nottinghamshire.
NG24 2ET
United Kingdom.

Declares that the product:

Description: Induction Loop Driver
Type name: ILD100

Conforms to the following Directive(s) and Norm(s):

Directive 89/336/EEC
EMC: EN55103-1 : 1997 Emission
EN55103-2 : 1997 Immunity
Directive 73/23/EEC
Safety: EN60065: 2002

Date October 2005
Leon Pieters
Technical Director,
Ampetronic Ltd.