

**This product may be purchased from Connevens Limited secure online store
at www.DeafEquipment.co.uk**



DeafEquipment.co.uk

Solutions to improve the quality of life



1

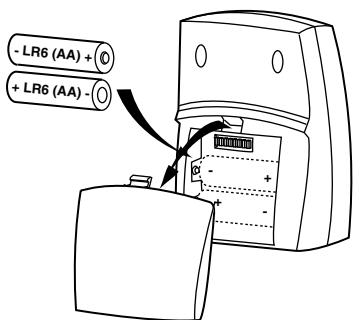

2

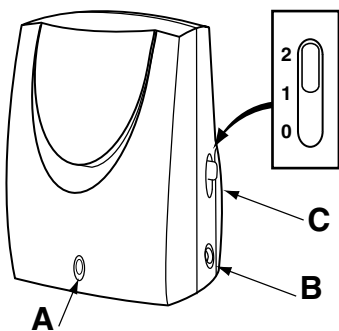

3

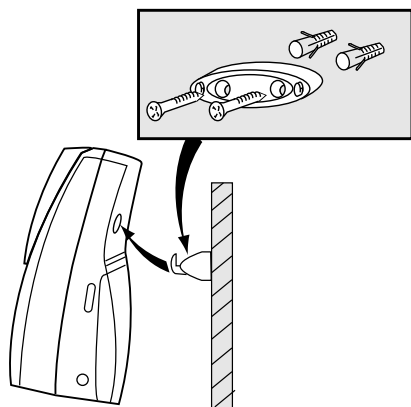

4

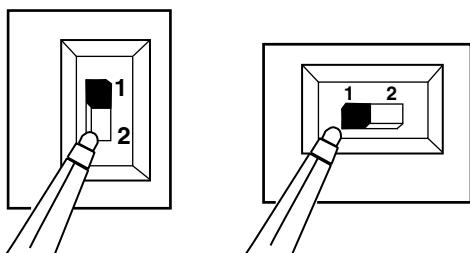

5

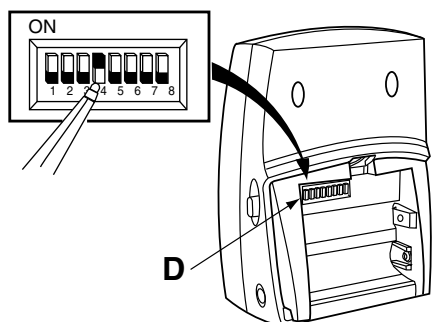

Libra Wirefree 100m Chime

Instructions for Model No. D285

GB

You Will Need

● 2 x LR6(AA) alkaline batteries for the Door-Chime. We recommend that only long-life alkaline batteries are used (eg Duracell or Energiser). This product will not work with NiCd rechargeable batteries.

Installation

Please note: positioning the Door Chime (or a Bell Push) on or near metal structures or reinforced PVCu doors or door frames may reduce the transmission range.

Remove the battery compartment cover and insert the two LR6(AA) alkaline batteries as shown in Diagram 1.

When these batteries need replacing, the Battery Low Warning Light (A in Diagram 2) will flash every 5 seconds.

The Door Chime can be free-standing or wall mounted using the wall bracket provided. If wall mounting is preferred, screw the bracket to the wall, Diagram 3. The Door Chime hooks onto the wall bracket as illustrated.

There is an external adapter socket (B in Diagram 2) which allows you to power the Door Chime receiver from a 220-240V mains socket using the Friedland Libra plug-in mains adapter which can be purchased separately (UK BRITISH STANDARD Plug Model No: D254, Euro Plug Model No: D258).

Tune Selection

Your Door-Chime can play a 2 note or 4 note sequence.

On your Friedland Libra Bell Push you will find a Tune Select Control similar to one of those in Diagram 4. If you require the 2 note sequence to be played move the Control to position 1. If you require the 4 note sequence move the Control to position 2.

Please note: The note sequence choice described above is not available when the Chime is being used with a Libra Handheld Pager, Model Number: D268.

Volume Control

The Volume Control (C in Diagram 2) enables you to adjust the volume of your Door Chime at any time or turn it off completely. The settings are:

- 2. High
- 1. Low
- 0. Mute

System Codes - VITAL INFORMATION

Friedland Libra products use a coding system to ensure that they work together and that there is no interference to or from a neighbouring Friedland wirefree product.

The system code in all Libra products is set using a series of 8 switches (D in Diagram 5).

In order for your new Chime to work with a Libra Bell Push and other Libra products, you will need to ensure that the system codes are adjusted to be the same by following this procedure:

1. Check switches 1 to 8 in your existing Libra products.
2. Look at the position of the switches (D in Diagram 5) in your new Chime.
3. If switches 1 to 8 are not in the same position change the switches in your new Chime to match those in your existing products using a pen tip, as illustrated in Diagram 5.

Example: if you set switch 1 in your Bell Push to the ON position, then you must set switch 1 in your Door Chime to the ON position.

In the unlikely event that your Door Chime rings without your Bell Push being used, it means another Friedland wirefree product, either your own or a neighbour's, is using the same system code as your own. You should change the system code in all your products in the same way as described above.

Other Libra Products

All Friedland Libra products are compatible and will activate each other if the system codes are set to be the same, as described above. For example, if you install an additional Libra Bell Push for your back door, just ensure that you adjust the system code to be the same as your other Bell Push and your Door Chime.

Movement Activated Door Chimes

Friedland Libra chimes can also be activated by a Friedland Spectra 433MHz PIR Movement Detector/ Transmitter. All you have to do is make sure that the PIR and Door Chime have the same system code.

Trouble Shooting

Problem	Possible Cause	Solution
Chime not sounding	Batteries may not be inserted correctly	Check all batteries have been inserted correctly
	Chime may be positioned out of range of the Bell Push	Move your Chime closer to the Bell Push
	A metallic object may be blocking the signal from the Bell Push	Experiment with the location of your Chime to see if you can position it in a more suitable place
	The battery in the Bell Push may need replacing	Replace the Bell Push battery
	Your Bell Push and Chime may have different system codes	Check the system codes in both your Chime and Bell Push
	Your volume control may be set to the mute setting	Set volume control to position 1 or 2
False activation of the Chime	Another of your own or a neighbour's wirefree product may be using the same code	Change the system codes in both your Bell Push and Chime

Caradon Friedland guarantees this product for 3 years from date of purchase. This does not effect your statutory rights.

If you require further information about Libra products, call the Friedland helpline on 0161 432 0277 ext 888.