

**This product may be purchased from Connevens Limited secure online store
at www.DeafEquipment.co.uk**



DeafEquipment.co.uk

Solutions to improve the quality of life



WIRING DIAGRAM FOR CONNECTION OF THE Ei169 ALARM FOR THE DEAF TO THE VOLT FREE RELAY CONTACTS OF A 24V FIRE ALARM SYSTEM

INSTALL THE CONTROL PANEL (Ei173) IN ACCORDANCE WITH THE INSTRUCTIONS SUPPLIED WITH THE PRODUCT - IGNORING THE SMOKE ALARM INSTALLATION REQUIREMENTS

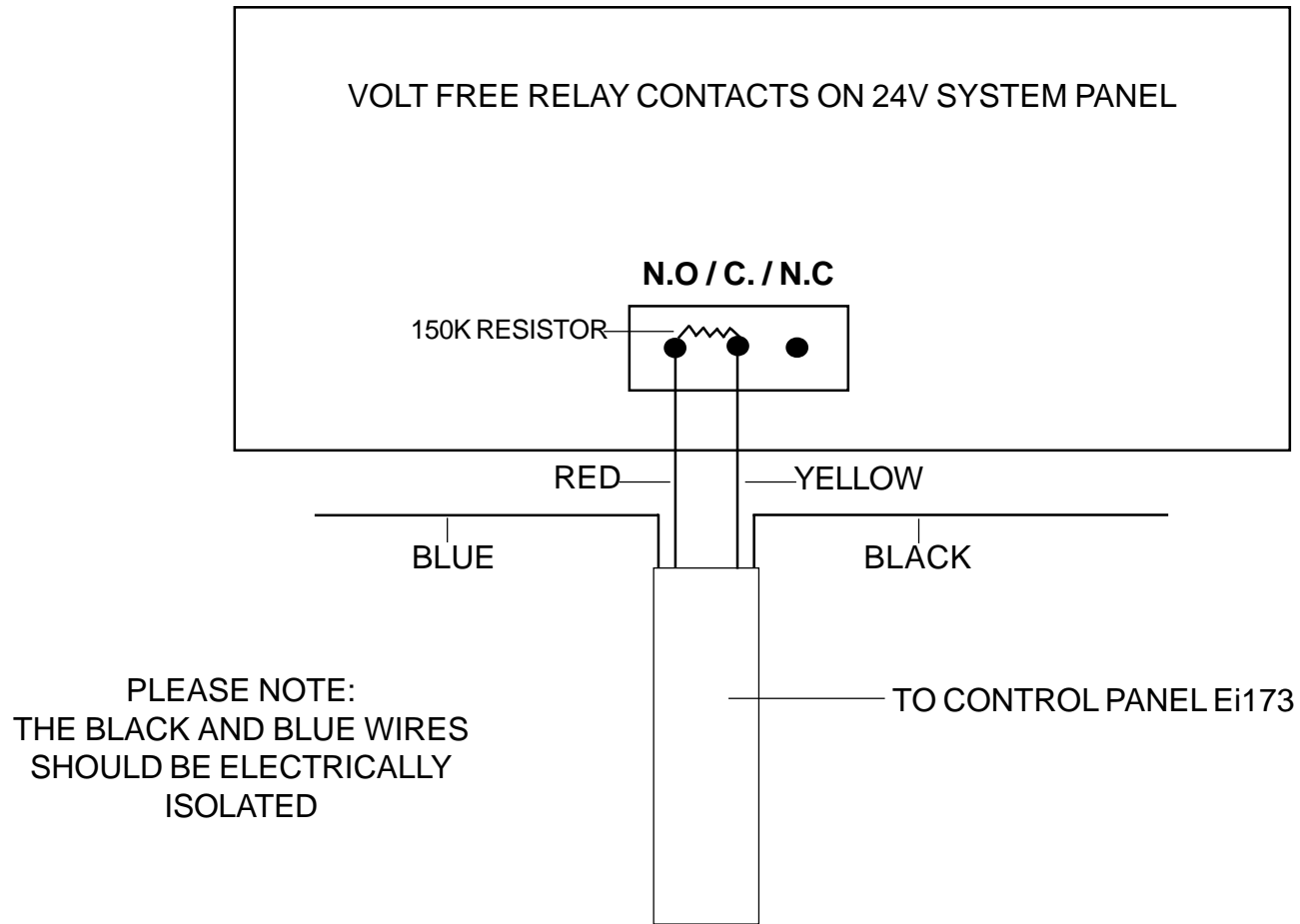

WIRING DIAGRAM TO CONNECT AN Ei169 OR Ei169/160 DEAF ALARM TO A 24V ALARM SYSTEM

