

**This product may be purchased from Connevens Limited secure online store
at www.DeafEquipment.co.uk**



DeafEquipment.co.uk

Solutions to improve the quality of life



IF OTHER MODELS BEEP SEE PAGE 3 to 5.

- ✓ TEST WEEKLY - PRESS THE BUTTON FOR 10 SECONDS AND A RED LIGHT ON THE COVER SHOULD FLASH. INTERCONNECTED ALARMS WILL ALSO SOUND AFTER A FURTHER 5 SECONDS.
- ✓ CLEAN YOUR ALARM REGULARLY. THIS WILL REDUCE THE RISK OF FALSE ALARMS.
- ✓ REMOVE OR COMPLETELY COVER YOUR ALARM WHEN REDECORATING TO PREVENT DUST OR OTHER CONTAMINATION DAMAGING THE UNIT.
- ✗ DO NOT PAINT OR ALLOW PAINT, WATER OR DUST TO CONTAMINATE YOUR ALARM.
- ✗ YOUR ALARM IS A MAINS 230V AC ELECTRICAL APPLIANCE. DO NOT REMOVE THE COVER OR INSERT ANYTHING INTO THE ALARM.
- ? IF YOUR ALARM SOUNDS FOR NO REASON AND WILL NOT RESET, SWITCH OFF THE MAINS AND REMOVE BY RELEASING BASE CLIP & PUSHING COVER BACK. (SEE FIGURE 1, BELOW).

Figure 1a

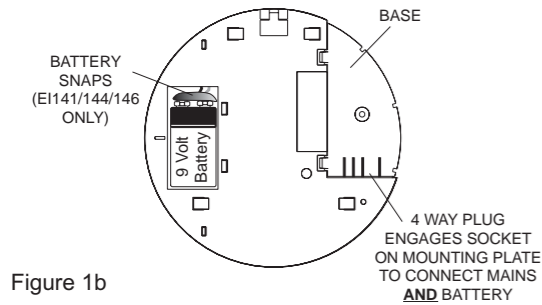
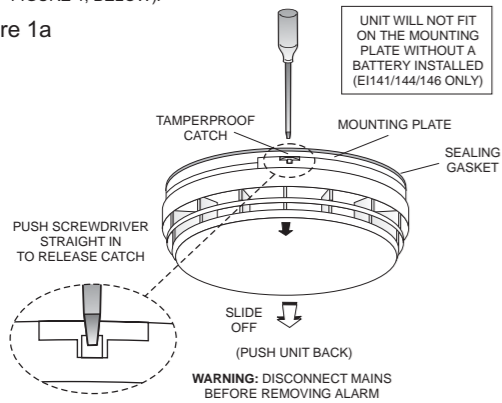

Figure 1b

2

INSPECTION & TESTING PROCEDURE

After installation and after re-occupation following a holiday etc. check all your Alarms weekly as follows:

- (i) Check that the green mains indicator light is on. (If it is off check circuit breakers, fuses and wiring etc.) Check the red light on the cover flashes every 40 seconds.
- (ii) Press the test button for up to 10 seconds to ensure the sensor chamber, electronics and sounder are working. A red light on the cover will flash while horn is sounding. The alarm will stop when the button is released. Pressing the test button simulates the effect of smoke or heat during a real fire and is the best way to ensure the Alarm is operating correctly.

WARNING: DO NOT TEST WITH FLAME.

This can set fire to the Alarm and damage the house.

We do not recommend testing with smoke or heat as the results can be misleading unless special apparatus is used.

Check for any sign of contamination such as cobwebs or dust and clean the alarm as described below if necessary.

Interconnected alarms

Test the first unit by pressing the button. All the detectors should alarm within about 5 seconds of the first horn sounding and the red light on the first unit only will flash once a second. Check all the other units similarly. (Note: Heat alarms signal to other interconnected alarms about 4 seconds after their own horn sounds. Optical alarms signal within about a second.

Checking Battery Back-up

When the unit is beeping:

The Alarm automatically monitors the battery every 40 seconds to ensure that it is satisfactory. If it is depleted it will give a short beep every 40 seconds.

Models Ei144 & Ei146 only

Before replacing the battery, check that the beeps are not due to one of the following:(i) battery snaps not connected properly.

- (ii) On the Optical Smoke Alarm only (EI 146/145) if the unit beeps and the red light does not flash at the same time it indicates a problem with the smoke chamber - see Cleaning the Smoke Alarm section below.

If the beeps have continued for over 20 minutes (and the other causes of beeps have been ruled out - see below) the battery must be replaced.

- (iii) Switch off the mains and remove the unit as shown in figure 1a. Remove depleted battery and replace with one of the specified 9V alkaline batteries. The alarm cannot be replaced on the mounting plate unless a battery is installed.

3

After replacing the battery, slide on the mounting plate then press the test button and ensure horn sounds loudly before you turn on the mains. If it is satisfactory turn on the mains and check that the green light comes on. Note: Only use the specified Alkaline batteries shown on the base label (Duracell MN1604 or Eveready 522). We recommend that the "use by date" on the battery should still have at least 2 years to go. Older batteries will give beeps prematurely.

We recommend that the battery is replaced each year for optimum performance.

Models Ei164 & EI 166 only

- (i) Check that the green mains power light is on. If it is off the Alarm has been powered from the cells and the beeps indicate they are depleted. Re-connect the mains, check fuse, circuit breakers and wiring. If in doubt contact a qualified electrician. The beeps should cease within 2 hours as the cells charge up.

- (ii) The cells may be depleted. The beeps should cease within 2 hours as they charge up. Fully charged, the cells will provide up to 6 months back-up without mains power.

- (iii) On the Optical Smoke Alarms only (EI 166) if the unit beeps and the red light does not flash at the same time it indicates a problem with the smoke chamber - see Cleaning the Smoke Alarm.

If all of the above possible causes of beeps have been ruled out but the beeping has still persisted for over 2 hours with the green light on - the rechargeable cells are probably defective. The Smoke / Heat Alarm must be returned to the manufacturer for repair or replacement (see section Getting Your Alarm Serviced).

(Please note: The Heat alarms (EI143/144/164) give two short beeps about a second apart at the end of the hush period (i.e. about 10 minutes after test/hush button has been pressed). These two beeps should not be confused with low battery beeps.

Caution: Do not tamper with the lithium battery cells or try to replace them. Danger of explosion if battery is incorrectly replaced .

2. Manual Testing:

Models: (Ei 144 / 146 / 164 only).

We recommend that the functioning of the mains battery backup is checked directly after installation and then at least yearly as follows:

- (i) Turn off the mains power at the distribution board and check that the green indicator light is extinguished.
- (ii) Press the test button and ensure the horn sounds loudly for 10 seconds. Turn on the mains supply at the distribution board only if the unit passes the above test.

Note: If the mains is disconnected and the battery is almost depleted the unit will beep every 40 seconds for at least 30 days.

4

The unit will operate from the mains alone, even with a fully depleted or a defective battery (and give beeps every minute), though it may not give sufficient warning of fire if the mains supply is disconnected for any reason. If there are any problems get a qualified electrician to inspect the house wiring and connections to the alarms. If there are still problems the unit must be returned for examination (see section on Getting Your Smoke Alarm Serviced below).

CLEANING YOUR ALARM

WARNING: Electrical shock hazard. Disconnect the AC mains at the fuse box or circuit breaker powering the Alarm before following the cleaning instructions.

Clean your Alarm regularly, particularly in dusty areas. Use the narrow nozzle attachment of your vacuum cleaner to remove dust, insects and cobwebs from the sides and cover slots where the smoke or heat enters. To clean the cover, wipe with a damp cloth. Dry cover thoroughly with a lint free cloth.

WARNING: Do not paint your Alarm.

Other than the cleaning described above, no other customer servicing of this product is required. Repairs, when needed, must be performed by the manufacturer.

All Alarms are prone to dust and insect ingress which can cause false alarms or failure to alarm.

The latest design, materials and manufacturing techniques have been used in the construction of our Alarms to minimize the effects of contamination. However it is impossible to completely eliminate the effect of dust and insect contamination, and therefore, to prolong the life of the Alarm you must ensure that it is kept clean so that excess dust does not build up. Any insects or cobwebs in the vicinity of the Alarm should be promptly removed.

In certain circumstances even with regular cleaning, contamination can build up in the smoke sensing chamber causing the alarm to sound or fail. If this happens the alarm must be returned to us for servicing or replacement. Contamination is beyond our control, it is totally unpredictable and is considered normal wear and tear. For this reason, contamination is not covered by the guarantee and a charge is made for servicing such units.

NUISANCE ALARMS

If there is a nuisance alarm simply press the test/hush button on the Alarm to silence the unit for 10 minutes.

If, when the alarm goes off, there is no sign of smoke, heat or noise to indicate that there is a fire, you should get your family into a safe place, before you start investigating.

5

Check the house carefully in case there is a small fire smouldering somewhere.

Check whether there is some source of smoke or fumes, for example cooking fumes being drawn past the Smoke Alarm by an extractor.

If there are frequent nuisance/false alarms it may be necessary to re-locate the device away from the source of the fumes. If for some reason the alarm continues to sound without smoke or heat being present (due to insect infestation or contamination build-up for example) the units can be silenced by disconnecting the mains power and removing the unit (see figure 1). If cleaning the Alarm does not correct the problem it can be returned to the manufacturer for repair or replacement (see Getting Your Alarm Serviced below).

Hush Feature

All the Smoke Alarms have a combined Test/Hush Button to help you control nuisance false alarms.

1. To cancel a false alarm, press the Test/Hush Button located on the cover. The Alarm will automatically switch to a reduced sensitivity condition (very large levels of smoke from a nearby fire will override the Hush on the smoke alarms). This condition allows unwanted alarms to be silenced for a period of approximately 10 minutes.

The unit will flash the red light every 10 seconds (instead of the normal 40 seconds) to indicate the sensitivity is reduced. At the end of the hush period the Heat Alarms (EI 144/143) will give two short beeps.

On interconnected Alarms, pressing the Test/Hush Button on the one sensing smoke (i.e. the one with the red light flashing every second) will silence all alarms. Pressing the Hush Button on any other Alarm will not cancel the alarm.

2. The unit will reset to normal sensitivity at the end of the silenced period. If additional silenced time is required, simply push the Test/Hush Button again.

IMPORTANT SAFEGUARDS

When using household protective devices, basic safety precautions should always be followed, including those listed below:

- Please read all instructions.
- Rehearse emergency escape plans so everyone at home knows what to do in case the alarm sounds.
- NOTE: Constant exposure to high or freezing temperatures or high humidity may reduce the life of the battery.
- To maintain sensitivity to smoke, do not paint or cover smoke alarm in any manner; do not permit any accumulation of cobwebs, dust or grease.

- If the unit has been damaged in any way or does not function properly, do not attempt a repair. Return Alarm (see - Getting your Alarm Serviced).
- This appliance is only intended for premises having a residential type environment.
- Smoke / Heat Alarms are not a substitute for insurance. The supplier or manufacturer is not your insurer.
- Do not dispose of your Alarm in a fire.

PLANNING YOUR ESCAPE ROUTE FOR WHEN THE ALARM GOES OFF

Use the Smoke / Heat Alarm Test Buttons to familiarize your family with the Alarm sound and to practice fire drills regularly with all family members. Draw up a floor plan that will show each member at least 2 escape routes from each room in the house. Children tend to hide when they don't know what to do. Teach children how to escape, open windows, and use roll up fire ladders and stools without adult help. Make sure they know what to do if the alarm goes off - see below.



1. Check room doors for heat or smoke. Do not open a hot door. Use an alternate escape route. Close doors behind you as you leave.



2. If smoke is heavy, crawl out, staying close to floor. Take short breaths, if possible, through a wet cloth or hold your breath. More people die from smoke inhalation than from flames.



3. Get out as fast as you can. Do not stop for packing. Have a prearranged meeting place outside for all family members. Check everybody is there.



4. Call the Fire Brigade from a neighbour's house. Remember to give your name and address.



5. NEVER re-enter a burning house.

Limitations of Smoke / Heat Alarms

Smoke / Heat Alarms have significantly helped to reduce the number of fire fatalities in countries where they are widely installed.

However independent authorities have stated that they may be ineffective in some circumstances. There are a number of reasons for this:

- The Alarms will not work if the mains power is off and the back-up battery is depleted. On the EI141/144/146 alarms the batteries should be replaced annually and when the unit gives a low battery beep.
- Smoke/Heat Alarms will not detect fire if sufficient smoke / heat does not reach the alarm. Smoke/Heat may be prevented from reaching the Alarm if the fire is too far away, for example, if the fire is on another floor, behind a closed door, in a chimney, in a wall cavity, or if the prevailing air draughts carry the smoke / heat away. Installing Smoke/Heat Alarms on both sides of closed doors and installing more than one Smoke/Heat Alarm as recommended in the 'Siting & Installation leaflet' very significantly improves the probability of early detection.
- The Alarm may not be heard.
- A Smoke / Heat Alarm may not wake a person who has taken drugs or alcohol.
- Smoke / Heat Alarms may not detect every type of fire to give sufficient early warning. They are particularly ineffective with: fires caused by smoking in bed, escaping gas, violent explosions, poor storage of flammable rags and/or liquids, (for example petrol, paint, spirits etc), overloaded electrical circuits, arson and children playing with matches.

Fire Authorities (including the Home Office, UK) recommend that both Optical and Ionisation Smoke Alarms should be fitted for the fastest response to all types of fires.

Smoke / Heat Alarms don't last indefinitely. For example if there is a build up of contamination, performance will be impaired.

The manufacturer recommends replacement of the Smoke / Heat Alarms after 10 years as a precaution.

GETTING YOUR ALARM SERVICED

If your Alarm fails to work after you have carefully read all the instructions, checked the unit has been installed correctly, and is receiving AC power (green light on) contact Customer Assistance at the address given at the end of this leaflet. If it needs to be returned for repair or replacement put it in a padded box and send it to "Customer Assistance and Information" at the nearest address given on the Alarm or in this leaflet. Do not snap on the mounting plate as this connects the battery and the unit may beep or alarm in the post. State the nature of the fault, where the Alarm was purchased and the date of purchase.

FIVE YEAR PRODUCT GUARANTEE

EI Electronics Ltd. guarantees this Alarm (excluding the battery on the EI141/144/146 models) for five years from date of purchase against any defects that are due to faulty materials or workmanship. This guarantee only applies to normal conditions of use and service, and does not include damage resulting from accident, neglect, misuse, unauthorised dismantling, or contamination howsoever caused. This guarantee excludes incidental and consequential damage. This guarantee does not cover costs associated with the removal and/or installation of alarms. If this Alarm should become defective within the guarantee period, it must be returned to EI Electronics, with proof of purchase, carefully packaged, with the problem clearly stated. (see "Getting Your Alarm Serviced") We shall at our discretion repair or replace the faulty unit.

Do not interfere with the Alarm or attempt to tamper with it. This will invalidate the guarantee, but more importantly may expose the user to shock or fire hazards.

This guarantee is in addition to your statutory rights as a consumer.

Aico Ltd., Mile End Business Park,
Maesbury Rd, Oswestry, Shropshire SY10 8NN, U.K.
Telephone : 0870 758 4000
www.aico.uk

EI Electronics. Shannon, Co Clare, Ireland.
www.eielectronics.com

TROUBLESHOOTING CONT.

4. INTERCONNECTED ALARMS DO NOT ALL SOUND:
- (1) Hold test button for 10 seconds after first alarm has sounded to ensure signal is transmitted to all units.
 - (2) Switch off mains and check that live, neutral and interconnect cables have been correctly connected and that the connections are tight.

TROUBLESHOOTING

1. FREQUENT NUISANCE ALARMS OCCUR:

- (1) Close kitchen / bathroom door when in use.
- (2) Ensure that the alarm is sited at least 6m away from sources of fumes.
- (3) Contamination from insects, paint or paint fumes may have occurred. Clean the alarm - see page 5.
- (4) If the problem persists, resiting of the unit should be considered.

2. ALARM SOUNDS FOR NO APPARENT REASON:

- (1) Identify the alarm source. On interconnected units, the red light on the cover will flash rapidly only on the unit which is the source of the alarm.
- (2) Check for fumes, steam etc. from the kitchen or bathroom. Paint and other fumes can cause nuisance alarms.
- (3) Press the test/hush button to silence the Smoke/Heat Alarm for 10 minutes.
- (4) If alarm does not stop, switch off mains and remove unit (see figure 1). (Only remove alarm with red light flashing, the others are probably satisfactory).

3. LOW BATTERY & OTHER BEEPS:

(On Ei144/146 only)

If the battery is correctly connected and the unit has beeped for over 20 minutes the battery is probably depleted. Obtain a new battery, disconnect the mains, then remove the alarm and replace the depleted battery.

(On Ei164/166 only)

Check the green mains power light is on. If not, check fuse, circuit breakers and wiring connections. If the green light is off, the lithium cells will deplete after some months without mains and will need to be recharged. If the above fails to turn on the green light, a fault may exist. Switch off mains and remove the unit (see figure 1).

(All Alarms)

- (1) If the green mains light is on and replacing battery, recharging lithium cells or cleaning unit has not stopped beeps, a fault may exist. Disconnect the mains first and replace the unit (see figure 1).
- (2) The Ionisation units Ei140/161) give two beeps 10 minutes after the test//hush button is pressed.
- (3) If the Optical units Ei 146/145/166) beeps without the red light flashing at the same time, the chamber is defective. Clean the chamber.



230V AC SMOKE & HEAT ALARMS



IONISATION	HEAT	OPTICAL
RECHARGEABLE LITHIUM CELL BACK-UP		
Ei161	Ei164	Ei166
ALKALINE 9 VOLT BATTERY BACK-UP		
Ei141	Ei144	Ei146
NO BATTERY BACK-UP		
Ei140	Ei143	Ei145

If you are also the installer see separate "Siting & Installation Instructions"

USER INSTRUCTIONS

KEEP FOR REFERENCE

READ THIS FIRST IMPORTANT USER INFORMATION

- REGULARLY CHECK THAT THE GREEN MAINS INDICATOR LIGHT IS ON.
- IF A NUISANCE ALARM OCCURS, PRESS THE TEST/HUSH BUTTON TO SILENCE THE ALARM FOR 10 MINUTES.
- IF THE UNIT BEEPS EVERY 40 SECONDS FOR OVER 20 MINUTES THE BATTERY IS PROBABLY DEPLETED AND MUST BE REPLACED. SWITCH OFF THE MAINS AND REMOVE THE UNIT AS SHOWN IN FIGURE 1A. REMOVE DEPLETED BATTERY AND REPLACE WITH ONE OF THE SPECIFIED 9V ALKALINE BATTERIES. THE UNIT CANNOT BE REPLACED ON THE MOUNTING PLATE UNLESS A BATTERY IS INSTALLED. AFTER REPLACING THE BATTERY, SLIDE ON TO THE MOUNTING PLATE THEN PRESS THE TEST BUTTON AND ENSURE HORN SOUNDS LOUDLY BEFORE YOU TURN ON THE MAINS. IF IT IS SATISFACTORY TURN ON THE MAINS AND CHECK THAT THE GREEN LIGHT COMES ON.