

**This product may be purchased from Connevens Limited secure online store  
at [www.DeafEquipment.co.uk](http://www.DeafEquipment.co.uk)**



**DeafEquipment.co.uk**

Solutions to improve the quality of life



AMPETRONIC

ILD9

## INDUCTION LOOP DRIVER

The Ampetronic ILD9 Induction Loop Driver is designed for a wide range of assistive listening applications where superior vocal and musical reproduction is paramount.

This Loop Driver sets the standard for constant-current drive in loop systems, providing a clean, high quality sound, with distortion levels well below those commonly associated with this type of equipment. The ILD9 is designed to be used with simple, single turn loops, offering ease of installation, combined with very small cable size to reduce visual impact. The single turn loop also allows a wide, flat frequency response to be reliably achieved.

A high performance Compressor (Automatic Gain Control), combined with wideband audio circuitry, maximises both music and speech reproduction for hearing aid users. While retaining the normal speech dynamics to maximise expression, the total dynamic range is reduced to a level more suitable for hearing aid users.

The system can also be used for many other applications, often in conjunction with separate loop receivers. These applications range from use in visitor guidance, to teaching, translation, overcoming noisy environments, etc.

LED metering of compression and loop current is provided on the front panel, with headphone monitoring of the loop current.

The ILD9 includes an innovative method to prevent generation of Radio Frequency Interference (RFI), due to output clipping. This is essential for loop systems to comply with EMC regulations. Patents for this method have been granted in a number of countries.

The equipment is very easy to install, and is robust and very reliable, having a long service record in a wide variety of locations.



The ILD9 Induction Loop Driver is designed to drive loops with areas up to 500 m<sup>2</sup>. With the ILC5 combining system, several units can be connected together in Master – Slave configuration to drive single – turn loops in much larger areas such as Cathedrals, sport halls and theatres. It can also be used for large conference rooms and other areas with special requirements such as low-spill installation or metal in the building construction. The specialised phased array loop layouts needed in these applications can be designed by Ampetronic Ltd. who also supply the precision phase shift unit needed for these designs to work correctly.

This ILD9 is designed to take its signal input from other sound systems, but Ampetronic supply also supply a range of accessory modules allowing independent loop systems to be installed.

## TECHNICAL SPECIFICATION

**Line Input:**

6.4 mm Jack socket, fully balanced (unbalanced with mono plug).  
Sensitivity: -40dBu overload at +10dBu.  
Overload protected CMRR > 50dB below 500Hz.

**Slave I/O:**

Insert point for connecting Ampetronic Phase Shifter, etc.  
Can be used as output for recording signal level 1 V RMS. (+2.7 dBu)

**Pre-amp power:**

±15V DC regulated output, up to 0.3A for powering Ampetronic Microphone Preamplifiers and external processors.

**Metal Loss Corrector:**

This control permits correction of the system frequency response when losses occur due to metal in the building. Loss adjustment is adjustable from 0 to 3 dB per octave, using 1 kHz as constant gain frequency. This does not compensate for the power loss caused by the metal.

**Compressor / AGC Control:**

30dB control range. Front panel indication in 6dB increments. Efficiency: <0.25dB output change for 25dB input change. Attack and Decay time constants optimised for speech.

**Loop Current:**

9.6A Peak signal current. Metering via front panel LEDs in 3dB increments.

**Output Voltage:**

Greater than 36 V peak, to enable good frequency response with larger, inductive loops. Patented circuitry prevents clipping to ensure EMC compliance.

**Loop Impedance:**

Designed for SINGLE-TURN loops, with DC resistance between 0.4 and 2 ..

**Area Coverage:**

The normal area that can be covered for a rectangular loop is 550m<sup>2</sup> (5900ft<sup>2</sup>). Where the aspect ratio is narrow and long, see handbook. If losses occur due

to metal or unusual loop position, then the area will be reduced. Please contact Ampetronic for advice.

**Frequency response:**

80Hz to 6.5kHz ±1.5dB at low level, measured as loop current. High frequency high signal level response is a function of loop size, loop current and signal content to ensure that no RFI generation takes place. Internal time constants are very short.

**AC Power input:**

230V AC nominal, 45-65Hz.  
115V AC version available  
160VA. Max power. Fuse T 1.6A 250V

**Cooling:**

Vertical airflow is required through a heatsink on the back panel; leave space above and below the unit.

**Dimensions:**

Length: 432mm  
Depth: 220mm  
Height: 88mm (2U)

**Weight:**

5.5kg.

**CE Compliance:**

The equipment meets all the applicable EMC and safety standards.

**Options:**

Rack mounts in 2 U space using RM9 brackets (see over for details).  
Loop Condition Monitoring.  
See special note below.

**LOOP CONDITION MONITORING.**

The ILD9 is now available with a factory fitted Loop Condition Monitoring option. This offers monitoring of both loop integrity and the equipment internal condition, allowing the equipment to be used with voice alarm systems. The status is signalled on a simple isolated contact for easy interface to a wide variety of monitoring systems.

For full details and prices, please contact us.

*The Complete System Capability*

AMPETRONIC

Ampetronic Ltd. Northern Road, Newark, Nottinghamshire. NG24 2ET United Kingdom

Tel: +44 (0) 1636 610062 Fax: +44 (0) 1636 610063



*5 Year Warranty*

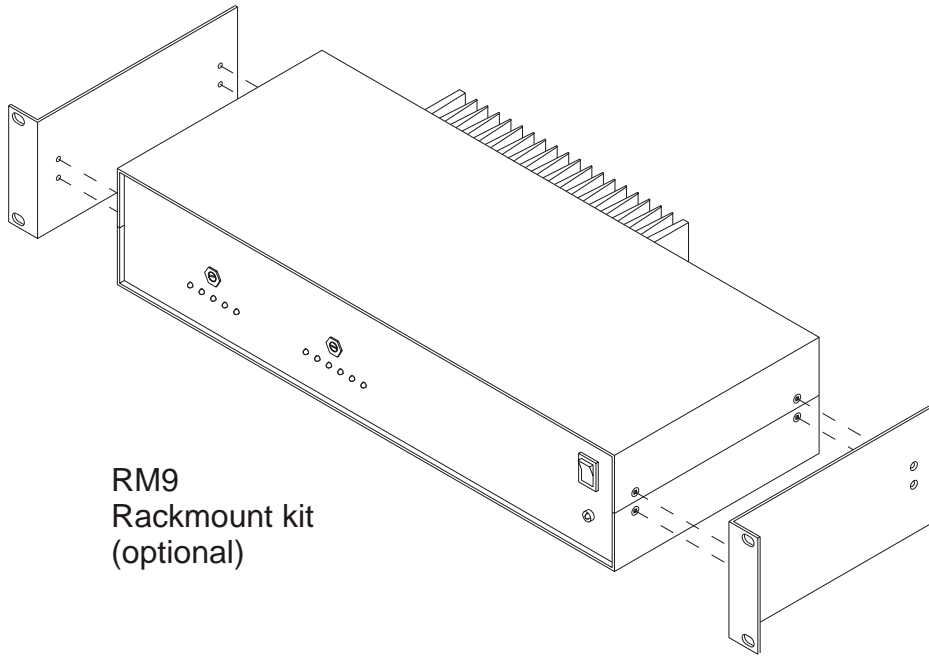

RM9  
Rackmount kit  
(optional)